

WELD *The TIG Welder's Choice* **CRAFT**®

Cooling System

**2500SS, 2502SS,
3500SS, 3502SS, CE3502SS,
6500SS, 6502SS, CE6502SS**

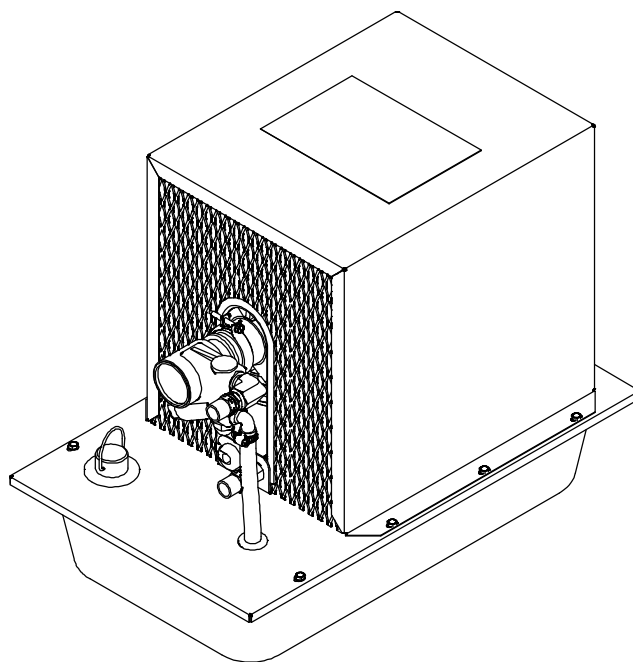

***Owner's Manual
Manuel de L'utilisateur
Manual del Operador***



Weldcraft.com
File: TIG (GTAW)



TABLE OF CONTENTS

SECTION 1 – SAFETY PRECAUTIONS – READ BEFORE USING	1
SECTION 2 – DEFINITIONS	3
2-1. Warning Label Definitions	3
2-2. Symbols And Definitions	4
2-3. WEEE Label (For Products Sold Within The EU)	4
SECTION 3 – SPECIFICATIONS	5
3-1. Important Information Regarding CE Products (Sold Within The EU)	5
3-2. 2500 Model Specifications	5
3-3. 3500 Model Specifications	5
3-4. 6500 Model Specifications	5
3-5. Serial Number And Rating Label Location	6
3-6. Coolant Chart	6
SECTION 4 – INSTALLATION	7
4-1. GTAW Connections	7
4-2. GMAW Connections	8
SECTION 5 – MAINTENANCE & TROUBLESHOOTING	9
5-1. Routine Maintenance	9
5-2. Coolant Maintenance	9
5-3. Adjusting Relief Valve	10
5-4. Troubleshooting	10
SECTION 6 – ELECTRICAL DIAGRAMS	11
SECTION 7 – PARTS	12

DECLARATION OF CONFORMITY



for European Community (CE marked) products.

Weldcraft, 2741 N. Roemer Rd., Appleton, WI 54911 U.S.A. declares that the product(s) identified in this declaration conform to the essential requirements and provisions of the stated Council Directive(s) and Standard(s).

Product/Apparatus Identification:

Product	Stock Number
3500 Cooler	CE3502SS

Council Directives:

2006/95/EC Low Voltage

2004/108/EC Electromagnetic Compatibility

Standards:

IEC 60974-1:2005 Arc welding equipment – Part 1: Welding power sources

IEC 60974-2:2008 Arc welding equipment – Part 2: Liquid cooling systems

IEC 60974-10:2007 Arc Welding Equipment – Part 10: Electromagnetic compatibility (EMC) requirements

EN 50445:2008 Product family standard to demonstrate compliance of equipment for resistance welding, arc welding and allied processes with the basic restrictions related to human exposure to electromagnetic fields (0 Hz – 300Hz)

US Signatory:

January 28, 2011

David A. Werba

Date of Declaration

MANAGER, PRODUCT DESIGN COMPLIANCE

DECLARATION OF CONFORMITY



for European Community (CE marked) products.

Weldcraft, 2741 N. Roemer Rd., Appleton, WI 54911 U.S.A. declares that the product(s) identified in this declaration conform to the essential requirements and provisions of the stated Council Directive(s) and Standard(s).

Product/Apparatus Identification:

Product	Stock Number
6500 Cooler	CE6502SS

Council Directives:

2006/95/EC Low Voltage

2004/108/EC Electromagnetic Compatibility

Standards:

IEC 60974-1:2005 Arc welding equipment – Part 1: Welding power sources

IEC 60974-2:2008 Arc welding equipment – Part 2: Liquid cooling systems

IEC 60974-10:2007 Arc Welding Equipment – Part 10: Electromagnetic compatibility (EMC) requirements

EN 50445:2008 Product family standard to demonstrate compliance of equipment for resistance welding, arc welding and allied processes with the basic restrictions related to human exposure to electromagnetic fields (0 Hz – 300Hz)

US Signatory:

January 28, 2011







David A. Werba

Date of Declaration

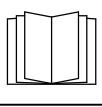

MANAGER, PRODUCT DESIGN COMPLIANCE

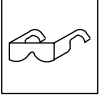
SECTION 1 – SAFETY PRECAUTIONS – READ BEFORE USING



rom _

	<p>DANGER! – Indicates a hazardous situation which, if not avoided, will result in death or serious injury. The possible hazards are shown in the adjoining symbols or explained in the text.</p> <p>DANGER! – Indique une situation dangereuse qui si on l'évite pas peut donner la mort ou des blessures graves. Les dangers possibles sont montrés par les symboles joints ou sont expliqués dans le texte.</p>		<p>Have only trained and qualified persons install, operate, or service this unit. Call your distributor if you do not understand the directions. For WELDING SAFETY and EMF information, read wire feeder and welding power source manuals.</p> <p>L'installation, l'exploitation et l'entretien de cet appareil doivent être confiés uniquement à des personnes qualifiées et convenablement formées. S'adresser à un distributeur si l'on ne comprend pas les directives. Pour des renseignements ayant trait à la SÉCURITÉ lors du soudage et aux champs électromagnétiques, consulter les manuels traitant les dévidoirs et les sources de courant pour le soudage.</p>
	<p>Indicates a hazardous situation which, if not avoided, could result in death or serious injury. The possible hazards are shown in the adjoining symbols or explained in the text.</p> <p>Indique une situation dangereuse qui si on l'évite pas peut donner la mort ou des blessures graves. Les dangers possibles sont montrés par les symboles joints ou sont expliqués dans le texte.</p>		<p>Beware of moving parts. Attention! Pièces en mouvement.</p>
<p>NOTICE</p> 	<p>Indicates statements not related to personal injury. Indique des déclarations pas en relation avec des blessures personnelles.</p> <p>Indicates special instructions. Indique des instructions spécifiques.</p>		<p>Wear safety glasses with side shields. Porter des lunettes de sécurité avec protections latérales.</p>
	<p>Beware of electric shock from wiring. Attention! Risque d'électrocution due au contact avec des fils.</p>		<p>Recycle or dispose of used coolant in an environmentally safe way. Recycler ou éliminer tout liquide de refroidissement utilisé conformément aux méthodes prescrites pour assurer la protection de l'environnement.</p>

California Proposition 65 Warnings

-  Welding or cutting equipment produces fumes or gases which contain chemicals known to the State of California to cause birth defects and, in some cases, cancer. (California Health & Safety Code Section 25249.5 et seq.)
-  This product contains chemicals, including lead, known to the state of California to cause cancer, birth defects, or other reproductive harm. *Wash hands after use.*
-  This product contains or produces a chemical known to the State of California to cause cancer or birth defects (or other reproductive harm). (California Health & Safety Code Section 25249.5 et seq.)

Proposition californienne 65 Avertissements

-  Les équipements de soudage et de coupage produisent des fumées et des gaz qui contiennent des produits chimiques dont l'État de Californie reconnaît qu'ils provoquent des malformations congénitales et, dans certains cas, des cancers. (Code de santé et de sécurité de Californie, chapitre 25249.5 et suivants)
-  Ce produit contient des produits chimiques, notamment du plomb, dont l'État de Californie reconnaît qu'ils provoquent des cancers, des malformations congénitales ou d'autres problèmes de procréation. *Se laver les mains après utilisation.*
-  Ce produit contient ou produit des éléments chimiques reconnus par l'État de Californie pour leur caractère cancérigène ainsi que provoquant des malformations congénitales ou autres problèmes de procréation. (Section 25249.5 et suivantes du «California Health & Safety Code».)

EMF INFORMATION

Electric current flowing through any conductor causes localized electric and magnetic fields (EMF). Welding current creates an EMF field around the welding circuit and welding equipment. EMF fields may interfere with some medical implants, e.g. pacemakers. Protective measures for persons wearing medical implants have to be taken. For example, access restrictions for passers-by or individual risk assessment for welders. All welders should use the following procedures in order to minimize exposure to EMF fields from the welding circuit:

1. Keep cables close together by twisting or taping them, or using a cable cover.
2. Do not place your body between welding cables. Arrange cables to one side and away from the operator.
3. Do not coil or drape cables around your body.
4. Keep head and trunk as far away from the equipment in the welding circuit as possible.
5. Connect work clamp to workpiece as close to the weld as possible.
6. Do not work next to, sit or lean on the welding power source.
7. Do not weld whilst carrying the welding power source or wire feeder.

About Implanted Medical Devices:

Implanted Medical Device wearers should consult their doctor and the device manufacturer before performing or going near arc welding, spot welding, gouging, plasma arc cutting, or induction heating operations. If cleared by your doctor, then following the above procedures is recommended.

Informations relatives aux CEM

Le courant électrique qui traverse tout conducteur génère des champs électromagnétiques (CEM) à certains endroits. Le courant de soudage crée un CEM autour du circuit et du matériel de soudage. Les CEM peuvent créer des interférences avec certains implants médicaux comme des stimulateurs cardiaques. Des mesures de protection pour les porteurs d'implants médicaux doivent être prises. Par exemple, des restrictions d'accès pour les passants ou une évaluation individuelle des risques pour les soudeurs. Tous les soudeurs doivent appliquer les procédures suivantes pour minimiser l'exposition aux CEM provenant du circuit de soudage:

- 1 Rassembler les câbles en les torsadant ou en les attachant avec du ruban adhésif ou avec une housse.
- 2 Ne pas se tenir au milieu des câbles de soudage. Disposer les câbles d'un côté et à distance de l'opérateur.
- 3 Ne pas courber et ne pas entourer les câbles autour de votre corps.
- 4 Maintenir la tête et le torse aussi loin que possible du matériel du circuit de soudage.
- 5 Connecter la pince sur la pièce aussi près que possible de la soudure.
- 6 Ne pas travailler à proximité d'une source de soudage, ni s'asseoir ou se pencher dessus.
- 7 Ne pas souder tout en portant la source de soudage ou le dévidoir.

En ce qui concerne les implants médicaux :

Les porteurs d'implants doivent d'abord consulter leur médecin avant de s'approcher des opérations de soudage à l'arc, de soudage par points, de gougeage, du coupage plasma ou de chauffage par induction. Si le médecin approuve, il est recommandé de suivre les procédures précédentes.

SECTION 2 – DEFINITIONS

2-1. Warning Label Definitions









The diagram S-180 663 is a grid of warning symbols. The top row contains five symbols: 1. A large exclamation mark in a triangle on a red background. 2. A person being struck by a moving part. 3. Hands being cut by a wire. 4. Hands being cut by a fan. 5. Safety glasses. The bottom row contains four symbols: 6. A hand plugging a cord into a power outlet. 7. A hand disconnecting a power cord. 8. A recycling symbol. 9. A hand painting over a label.

<p>1 Warning! Watch Out! There are possible hazards as shown by the symbols.</p> <p>2 Electric shock from wiring can kill.</p> <p>3 Disconnect input plug or power before working on machine.</p>	<p>4 Moving parts, such as fans, can cut fingers and hands and cause injury. Keep away from moving parts.</p> <p>5 Wear safety glasses with side shields.</p> <p>6 Read the Owner's Manual before working on this machine.</p> <p>7 Read the labels on the welding power</p>	<p>source, wire feeder, or other major equipment for welding safety information.</p> <p>8 Recycle or dispose of used coolant in an environmentally safe way.</p> <p>9 Do not remove or paint over (cover) the label.</p>
---	--	--

The diagram S-178 910 is a grid of warning symbols. The top row contains three symbols: 1. A large exclamation mark in a triangle on a red background. 2. Hands being cut by a wire. 3. Safety glasses. The middle row contains two symbols: 4. A hand plugging a cord into a power outlet. 5. A hand disconnecting a power cord. The bottom row contains two symbols: 6. A hand cleaning a filter. 7. A hand holding a coolant bottle. The coolant bottle is labeled with '043 810 (HF)' and '043 809 (AL)'. A box labeled '100 h. std.' is positioned above the filter symbol.

<p>1 Warning! Watch Out! There are possible hazards as shown by the symbols.</p> <p>2 Disconnect input plug or power before working on machine.</p> <p>3 Wear safety glasses with side shields.</p> <p>4 Plugged filter or hoses cause</p>	<p>overheating and damage.</p> <p>5 Read Owner's Manual.</p> <p>6 Check and clean filter every 100 hours; also check condition of hoses.</p> <p>7 Use Low Conductivity Coolant No. 043 810 for High-Frequency assisted or</p>	<p>Gas Tungsten Arc Welding applications. Use Aluminum Protecting Coolant No. 043 809 where coolant contacts aluminum parts or for Gas Metal Arc Welding applications or where High Frequency is not used.</p>
--	---	--

2-2. Symbols And Definitions

A	Amperes		Alternating Current		Voltage Input		Circulating Unit With Coolant Pump
V	Volts		Water (Coolant) Input		Water (Coolant) Output		Line Connection
	Protective Earth (Ground)	IP	Degree Of Protection	I₁	Primary Current	Hz	Hertz
I	On		Off	U₁	Primary Voltage		Single Phase

2-3. WEEE Label (For Products Sold Within The EU)

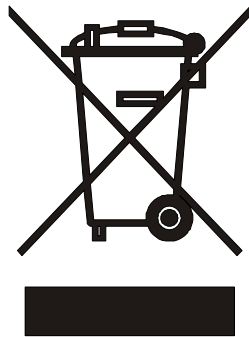

Do not discard product (where applicable) with general waste.

Reuse or recycle Waste Electrical and Electronic Equipment (WEEE) by disposing at a designated collection facility.

Contact your local recycling office or your local distributor for further information.

SECTION 3 – SPECIFICATIONS

3-1. Important Information Regarding CE Products (Sold Within The EU)

⚠ This equipment shall not be used by the general public as the EMF limits for the general public might be exceeded during welding.

This equipment is built in accordance with EN 60974-1 and is intended to be used only in an occupational environment (where the general public access is prohibited or regulated in such a way as to be similar to occupational use) by an expert or an instructed person.

Wire feeders and ancillary equipment (such as torches, liquid cooling systems and arc striking and stabilizing devices) as part of the welding circuit may not be a major contributor to the EMF. See the Owner's Manuals for all components of the welding circuit for additional EMF exposure information.

- The EMF assessment on this equipment was conducted at 0.5 meter.
- At a distance of 1 meter the EMF exposure values were less than 20% of the permissible values.

3-2. 2500 Model Specifications

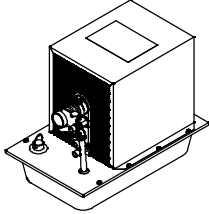
	Recirculating Coolant System For Water-Cooled GTAW Torches And GMAW Guns
	2 gal (7.6 L) Coolant Tank Capacity; Maximum Cooling Capacity: 2,519 W (8,595 BTU/hr) @ 7.6 qt/min (7.2 L/min)
	Dimensions: 16-7/8 in. (429 mm) Long, 10-1/2 in. (267 mm) Wide, 14 in. (356 mm) High Weight: 29.3 lb (13.3 kg)
	115 Volt Models Use 6.4 Amperes, 50/60 Hertz, Single-Phase Input Power 230 Volt Models Use 3.2 Amperes, 50/60 Hertz, Single-Phase Input Power

3-3. 3500 Model Specifications

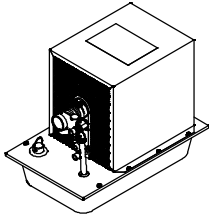
	Recirculating Coolant System For Water-Cooled GTAW Torches And GMAW Guns
	IEC IP Rating: 23 – Not Intended For Use In Heavy Rain, Or Near Splashing Water
	3 gal (11.4 L) Coolant Tank Capacity; Maximum Cooling Capacity: 3,118 W (10,640 BTU/hr) @ 7.6 qt/min (7.2 L/min)
	IEC Cooling Capacity: 1,440 W (4,913 BTU/hr) @ 1.1 qt/min (1 L/min) IEC Cooling Capacity States That The Water Inlet Temperature Can Not Exceed 40° C Above Ambient Temperature At A 1L/ Min Flow Rate. Ratings Developed At An Ambient Temperature Of 20° C to 25° C. Operating Temperature is -10° C to 40° C.
	Dimensions: 21-1/4 in. (540 mm) Long, 13-1/8 in. (333 mm) Wide, 16-3/4 in. (425 mm) High Weight: 38 lb (17.2 kg)
	115 Volt Models Use 6.4 Amperes, 50/60 Hertz, Single-Phase Input Power 230 Volt Models Use 3.2 Amperes, 50/60 Hertz, Single-Phase Input Power

3-4. 6500 Model Specifications

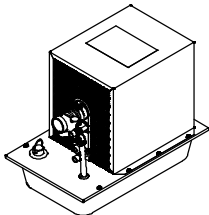
	Recirculating Coolant System For Water-Cooled GTAW Torches And GMAW Guns
	IEC IP Rating: 23 – Not Intended For Use In Heavy Rain, Or Near Splashing Water
	6 gal (22.7 L) Coolant Tank Capacity; Maximum Cooling Capacity: 3,625 W (12,370 BTU/hr) @ 7.6 qt/min (7.2 L/min)
	IEC Cooling Capacity: 1,580 W (5,391 BTU/hr) @ 1.1 qt/min (1 L/min) IEC Cooling Capacity States That The Water Inlet Temperature Can Not Exceed 40° C Above Ambient Temperature At A 1L/ Min Flow Rate. Ratings Developed At An Ambient Temperature Of 20° C to 25° C. Operating temperature is -10° C to 40° C.
	Dimensions: 21-1/4 in. (540 mm) Long, 13-1/8 in. (333 mm) Wide, 20-3/4 in. (527 mm) High Weight: 56 lb (25.4 kg)
	115 Volt Models Use 6.4 Amperes, 50/60 Hertz, Single-Phase Input Power 230 Volt Models Use 3.2 Amperes, 50/60 Hertz, Single-Phase Input Power

3-5. Serial Number And Rating Label Location

The serial number and rating information for this product is located on side panel of cover. Use rating label to determine input power requirements and/or rated output. For future reference, write serial number in space provided on back cover of this manual.

3-6. Coolant Chart

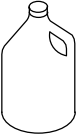
Application	GTAW Or Where HF* Is Used	GMAW Or Where HF* Is Not Used	Where Coolant Contacts Aluminum Parts
 Coolant	Low Conductivity Coolant Miller Part No. 043 810**; Distilled Or Deionized Water OK Above 32° F (0° C)	Low Conductivity Coolant Miller Part No. 043 810**; Or Aluminum Protecting Coolant Miller Part No. 043 809**; Distilled Or Deionized Water OK Above 32° F (0° C)	Aluminum Protecting Coolant Miller Part No. 043 809**

*HF: High Frequency Current

**Coolants 043 810 and 043 809 protect to -37° F (-38° C) and resist algae growth. Contact a Miller Electric Distributor to purchase either coolant 043 809 or 043 810.

NOTICE – Use of any coolant other than those listed in the table voids the warranty on any parts that come in contact with the coolant (pump, radiator, etc.).

SECTION 4 – INSTALLATION

4-1. GTAW Connections

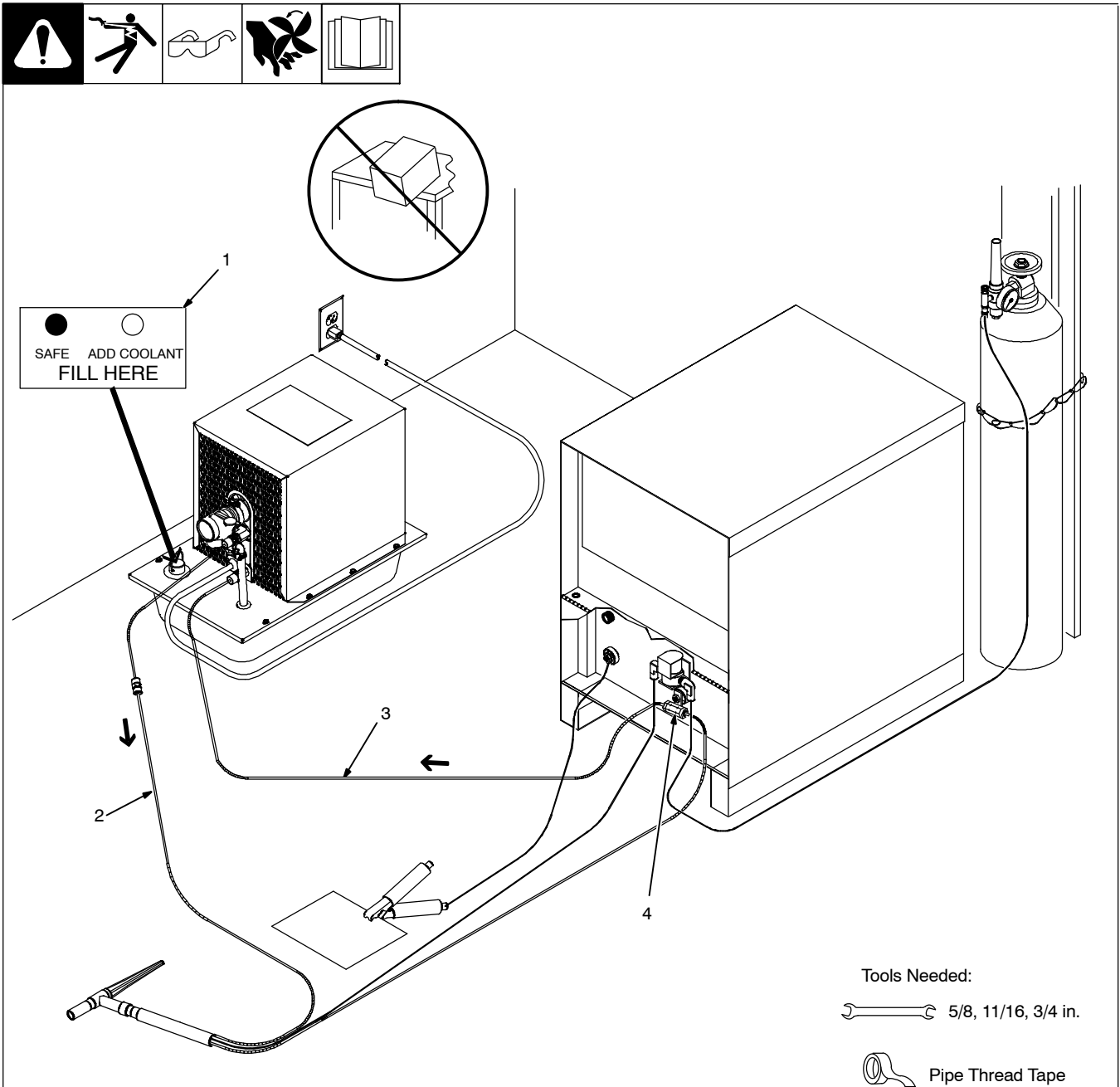

WC0134

⚠ Do not move or operate unit where it could tip.

NOTICE – To prevent overheating, make sure cooling unit is positioned so airflow is not restricted.

NOTICE – If welding power source has a water valve, do not connect hoses to water valve. Connect hoses as shown.

1 Fill Cap/Level Indicator

Use table in Section 3-6 to select proper coolant, and fill tank. Machine is full when indicator turns black.

2 Coolant Out Hose

3 Coolant In Hose

Fittings have 1/4 in. NPT and 5/8-18 left-hand adapters. Connect hoses with proper fittings as shown.

4 TIG Block

Customer supplied for use with some welding power sources, or use proper connector supplied with welding power source.

Operation:

Unit turns on when plugged in.

4-2. GMAW Connections

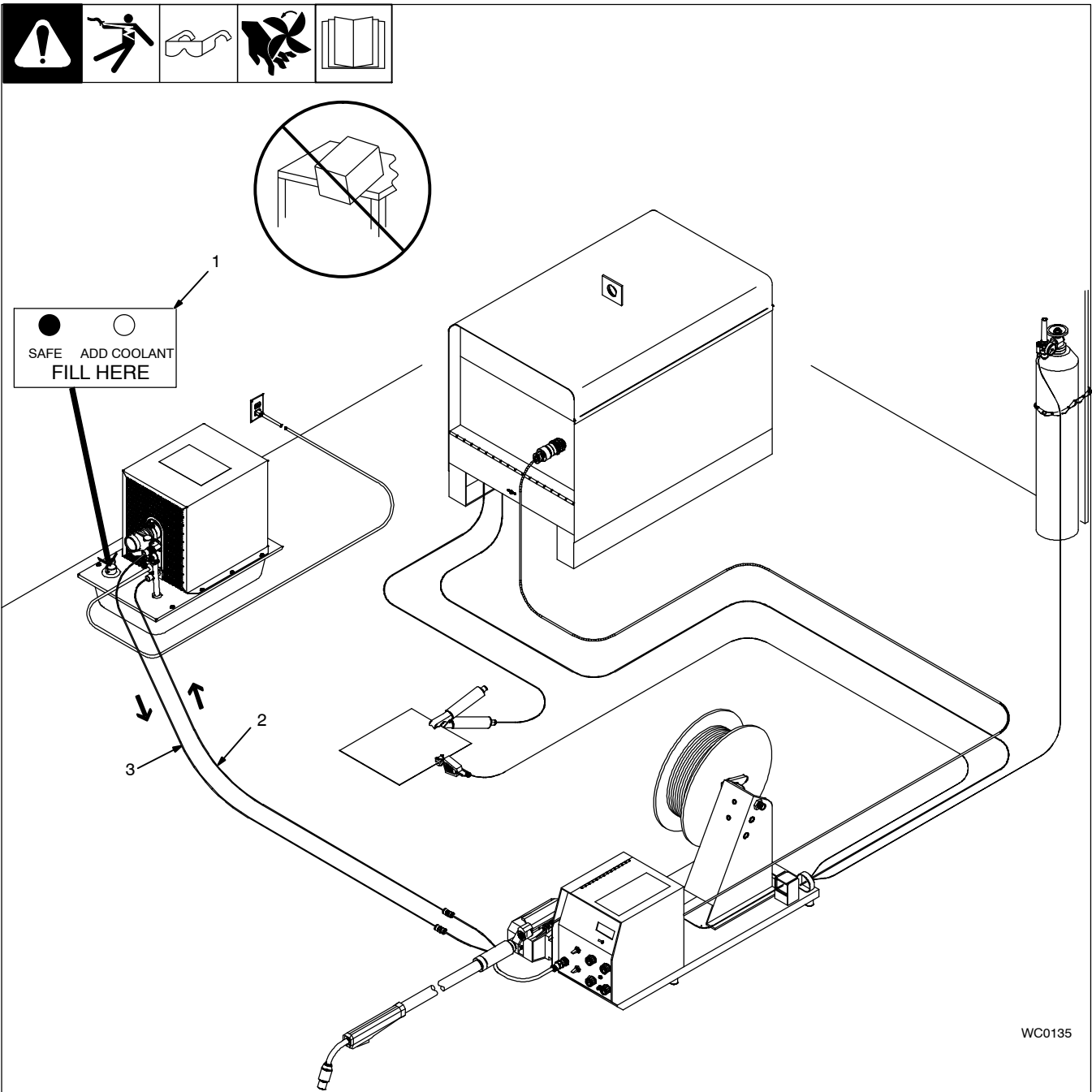

WC0135

Tools Needed:

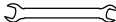
 5/8, 11/16, 3/4 in.

 Pipe Thread Tape

⚠ Do not move or operate unit where it could tip.

NOTICE – To prevent overheating, make sure cooling unit is positioned so airflow is not restricted.

1 Fill Cap/Level Indicator Label

Use table in Section 3-6 to select proper coolant, and fill tank. Machine is full when indicator turns black.

2 Coolant In Hose

3 Coolant Out Hose







Fittings have 1/4 in. NPT and 5/8-18 left-hand adapters. Connect hoses with proper fittings as shown.

Operation:

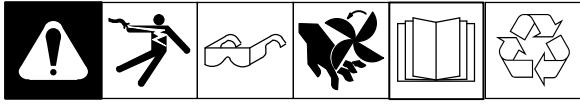
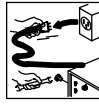

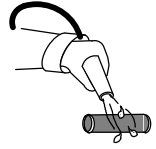
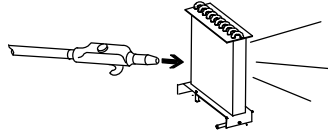
Unit turns on when plugged in.

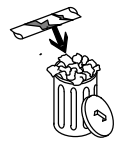
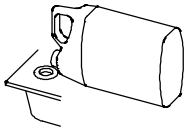
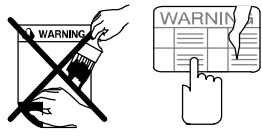
SECTION 5 – MAINTENANCE & TROUBLESHOOTING

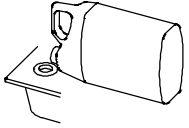
5-1. Routine Maintenance

 					
 3 Months					
 <p>NOTICE – Clean coolant strainer. Severe conditions may require more frequent cleaning (continuous use, high/low temperatures, dirty environment, etc.). Failure to properly clean coolant strainer voids pump warranty.</p>			 <p>Blow Out Heat Exchanger Fins</p>		
 6 Months					
 <p>Replace Cracked Hoses</p>		 <p>Change Coolant (If Using Water)</p>		 <p>Replace Unreadable Labels</p>	
 12 Months					
			<p>Change Coolant (If Using 043 809 or 043 810 Coolant)</p>		

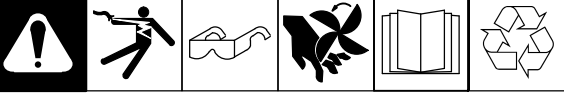
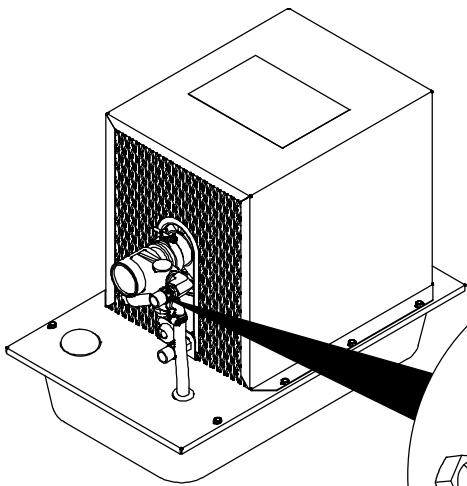
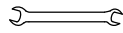
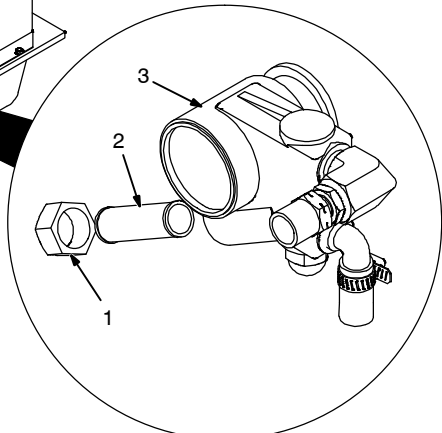
5-2. Coolant Maintenance

					
					
<p>Tools Needed:</p>  <p>5/16, 3/8, 15/16 in. or 24 mm</p>					
					
<ol style="list-style-type: none"> 1 Acorn Nut 2 Coolant Filter 3 Pump Body <p>Remove acorn nut.</p> <p>Remove and clean filter by rinsing with water, or with compressed air. Replace filter if damaged. Reinstall filter and acorn nut.</p> <p>Changing coolant:</p> <ul style="list-style-type: none"> • Pump existing coolant out of unit by disconnecting return hose and placing in a suitable container. • Disassemble and remove pan from bottom of unit. • Clean pan and reassemble. • Connect return hose to cooler. • Fill with clean water and run for 10 minutes. • Drain and refill (see Section 3-6). <p> If replacing hoses, use hoses compatible with ethylene glycol, such as Buna-n, Neoprene, or Hypalon. NOTE: Oxy-acetylene hoses are not compatible with any product containing ethylene glycol.</p>					

WC0136

5-3. Adjusting Relief Valve

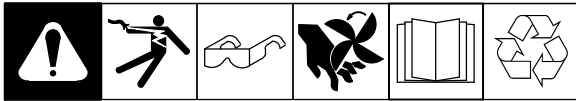

☞ Relief valve is factory set at 60 psi (414 kPa), and normally needs no adjustment: Only adjust if replacing motor.

- 1 Pressure gauge
- 2 Relief Valve Adjustment Screw

Connect gauge to Coolant Out fitting as shown. Block or plug any output fitting on gauge.

Turn On power, and adjust pressure adjustment screw as needed.

Turn Off power. Disconnect gauge and reinstall nut.

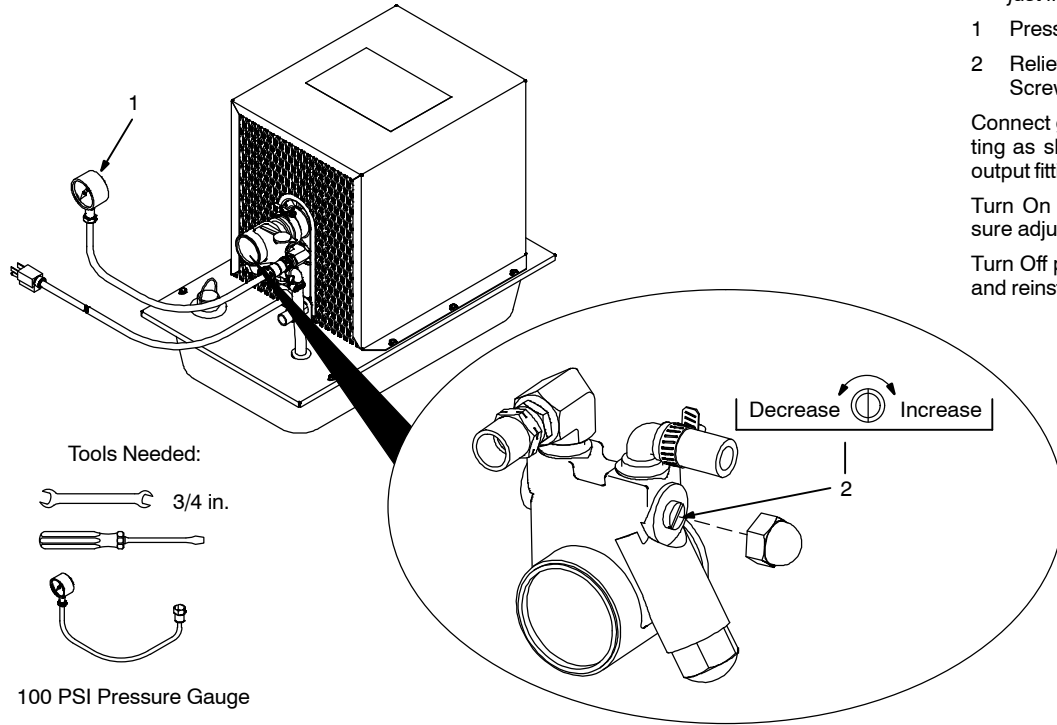

WC0137

5-4. Troubleshooting

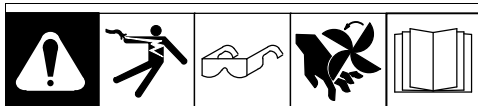

Trouble	Remedy
Coolant system does not work.	Be sure input power cord is plugged in to energized receptacle.
	Check line fuses or circuit breaker, and replace or reset if necessary.
	Motor overheated. Unit starts running when motor has cooled.
	Have Factory Authorized Service Agent check motor.
Decreased or no coolant flow.	Add coolant.
	Check for clogged hoses or coolant filter.
	Disconnect pump, and check for sheared coupling. Replace coupling if necessary.

SECTION 6 – ELECTRICAL DIAGRAMS

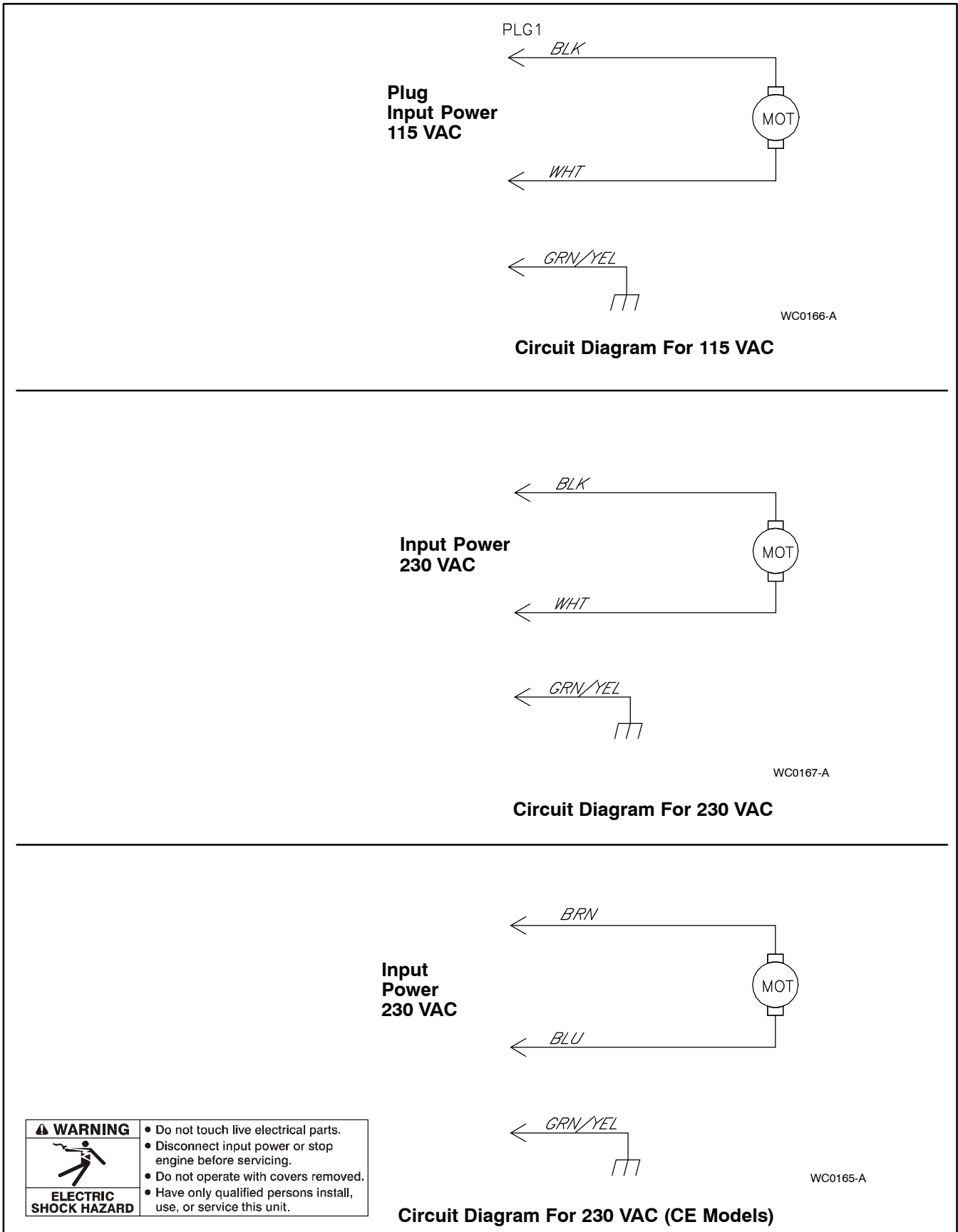
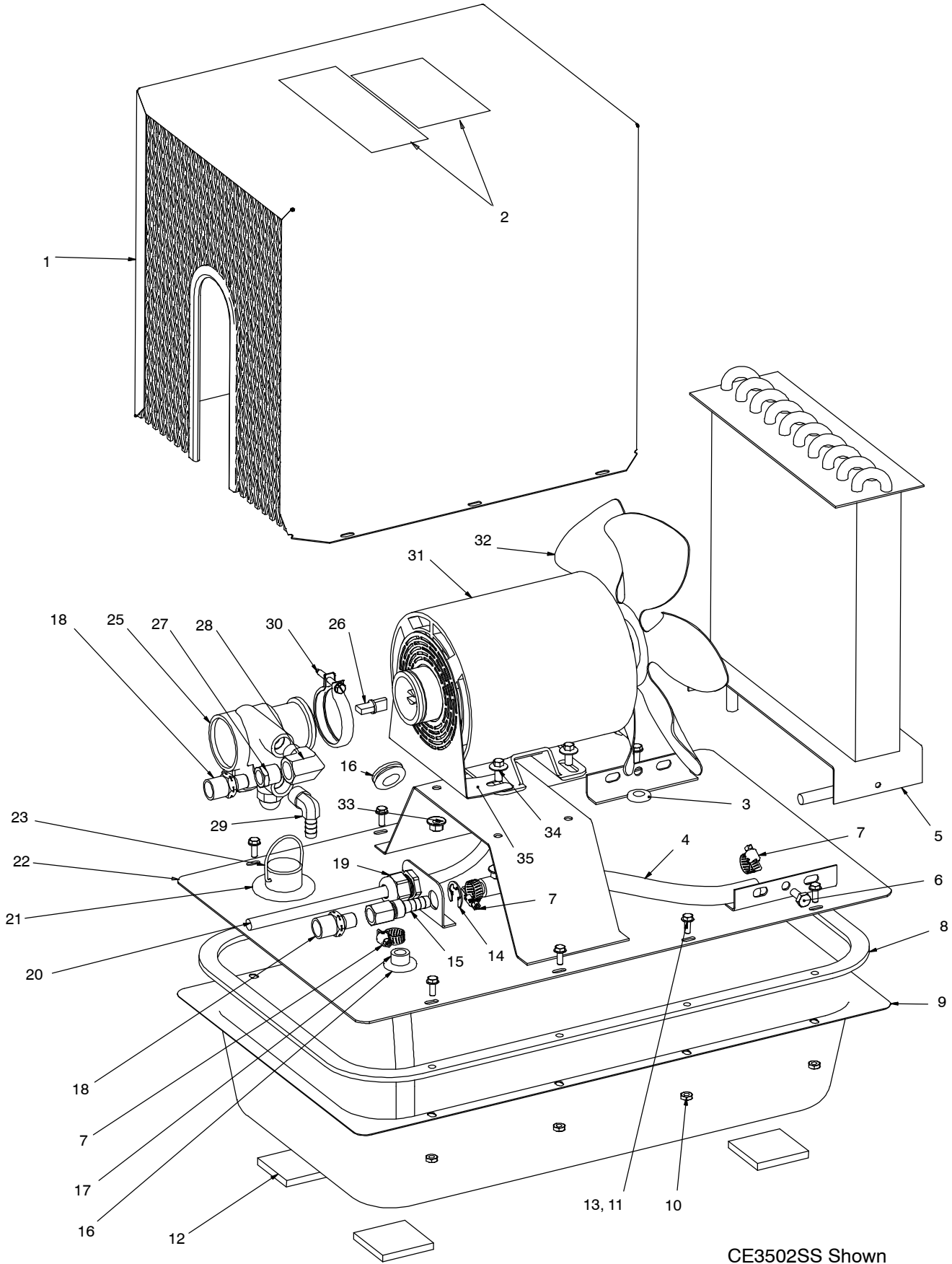

Figure 6-1. Circuit Diagrams

SECTION 7 – PARTS



CE3502SS Shown

Figure 7-1. Complete Assembly

Item No.	Dia. Mkgs.	Part No.	Description	Model No.							
				2500SS	2502SS	3500SS	3502SS	CE3502SS	6500SS	6502SS	CE6502SS
Figure 7-1 Complete Assembly.											
				Quantity							
1	+3583	Cover, Cooler	1	1	1	1	1	1	1
1	+1590025	Cover, Cooler	1	1					
2	WC0163	Label, Instructions, Generic	1	1	1	1	1	1	1
2	180663	..	Label, Warning General Precautionary					1		1
2	178910	..	Label, Warning Incorrect Coolant Wordless					1		1
3	3888	Grommet	1	1	1	1	1	1	1
4	3098H	..	Hose, 12-1/2 in.	1	1					
4	3098A	..	Hose, 10 in.			1	1	1	1	1
5	2230002	Radiator	1	1					
5	3880	Radiator			1	1	1		
5	GB0003	..	Radiator					1	1	1
6	1102	Bolt			3	3	3	3	3
7	010323	..	Clamp, Hose .250 - .625 Clp Dia	3	3	3	3	3	3	3
	2640007	Kit, Cooler Tank (Includes)	1	1					
8	3574	Gasket	1	1					
9	2640006	..	Tank, Coolant	1	1					
10	1374	Nut	8	8					
11	3596	Screw	8	8					
12	3329	Pad, Mounting	4	4					
13	WC0168	..	Washer, Tooth	6	6					
	3594	Kit, Cooler Tank (Includes)			1	1	1		
8	3574	Gasket			1	1	1		
9	3575	Tank, Coolant			1	1	1		
10	1374	Nut			8	8	8		
11	3596	Screw			8	8	8		
12	3329	Pad, Mounting			4	4	4		
13	WC0168	..	Washer, Tooth			6	6	6		
	2640004	Kit, Cooler Tank (Includes)					1	1	1
8	3574	Gasket					1	1	1
9	2640003	..	Tank, Coolant					1	1	1
10	1374	Nut					8	8	8
11	3596	Screw					8	8	8
12	3329	Pad, Mounting					4	4	4
13	WC0168	..	Washer, Tooth					6	6	6
14	2250006	Ring, Retaining	1	1	1	1	1	1	1
15	1720028	Adapter, Hose To Pipe	1	1	1	1	1	1	1
16	3558	Grommet	2	2	2	2	2	2	2
17	3098G	..	Hose, 7-1/2 in.	1	1					
17	3098B	..	Hose, 9 in.			1	1	1		
17	3098F	Hose, 13 in.					1	1	1
18	3066	Adapter, Hose Fitting	2	2	2	2	2	2	2
19	1429	Bushing, Strain Relief	1	1	1	1	1	1	1
20	1096	Cord, Power 115V	1		1		1		
20	1096-230	Cord, Power 230V			1		1		1
	CE1096	..	Assembly, Power Cord 230V (Includes)					1		1
19	CE1429	..	Bushing, Strain Relief					1		1
20	CE1097	..	Cord, Power CE					1		1
21	3889	Grommet	1	1	1	1	1	1	1
22	1590021	Assembly, Tank Top	1	1					
22	3582	Assembly, Tank Top			1	1	1	1	1
22	CE3582	..	Assembly, Tank Top					1		1
23	3683	Assembly, Level Indicator	1	1	1	1	1	1	1

Item No.	Dia. Mkgs.	Part No.	Description	Model No.								
				2500SS	2502SS	3500SS	3502SS	CE3502SS	6500SS	6502SS	CE6502SS	
Figure 7-1 Complete Assembly.												
				Quantity								
25		5515	Pump (Includes)	1	1	1	1	1	1	1	1	1
		*5557	Filter Screen, Replacement (Not Shown)	1	1	1	1	1	1	1	1	1
26		2220004	Coupling	1	1	1	1	1	1	1	1	1
27		3063	Reducer, 3/8 in. N.P.T.	1	1	1	1	1	1	1	1	1
28		3077	Elbow, 3/8 in N.P.T.	1	1	1	1	1	1	1	1	1
29		5523	Elbow, Hose 90 Deg	1	1	1	1	1	1	1	1	1
30		1066	Clamp, Motor To Pump	1	1	1	1	1	1	1	1	1
31	MOT	3429	Motor, 115V, 50/60 Hz, 1 PH	1		1				1		
31	MOT	3430	Motor, 230V, 50/60 Hz, 1 PH	1			1				1	1
32		166570	Blade, Fan w/Set Screw	1	1							
32		3000003	Blade, Fan w/Set Screw			1	1	1	1	1	1	1
33		152461	Nut	4	4	4	4	4	4	4	4	4
34		089799	Screw	4	4	4	4	4	4	4	4	4
35		CE0001	Motor Guard	1	1	1	1	1	1	1	1	1

+When ordering a component originally displaying a precautionary label, the label should also be ordered.

*Recommended spare part.

BE SURE TO PROVIDE MODEL AND SERIAL NUMBER WHEN ORDERING REPLACEMENT PARTS.



Owner's Record

Please complete and retain with your personal records.

Model Name

Serial/Style Number

Purchase Date

(Date which equipment was delivered to original customer.)

Distributor

Address

City

State

Zip



For Service

Contact a DISTRIBUTOR or SERVICE AGENCY near you.

Always provide Model Number.

Contact your Distributor for:

Welding Supplies and Consumables

Options and Accessories

Personal Safety Equipment

Service and Repair

Replacement Parts

Welding Process Handbooks

Weldcraft

An Illinois Tool Works Company
2741 N. Roemer Rd
Appleton, WI 54911 USA

1-800-752-7620 Toll Free

1-920-882-6800 Phone

1-920-882-6844 FAX

www.Weldcraft.com

To locate a Distributor or Service Agency call 1-800-752-7620 or 920-882-6800

Contact the Delivering Carrier to:

File a claim for loss or damage during shipment.

For assistance in filing or settling claims, contact your distributor and/or equipment manufacturer's Transportation Department.