

# WELDCRAFT®

## WP-20

250 AMPS • WATER COOLED

## WP-20P

225 AMPS • WATER COOLED

## WP-25

200 AMPS • WATER COOLED

## REPLACEMENT PARTS

**ACCESSORY KIT - AK-4, AK-4A (20P,25)**  
**CABLE COVERS - WC-3-10, WC-3-22**  
**EXTENSION KIT - EK-1-25**  
**HOO-K-UP KIT - HK-1, QHK-1 (QCS)**  
**QUICK CONNECT - ADD Q IN FRONT OF TORCH PACKAGE OR CABLE #**

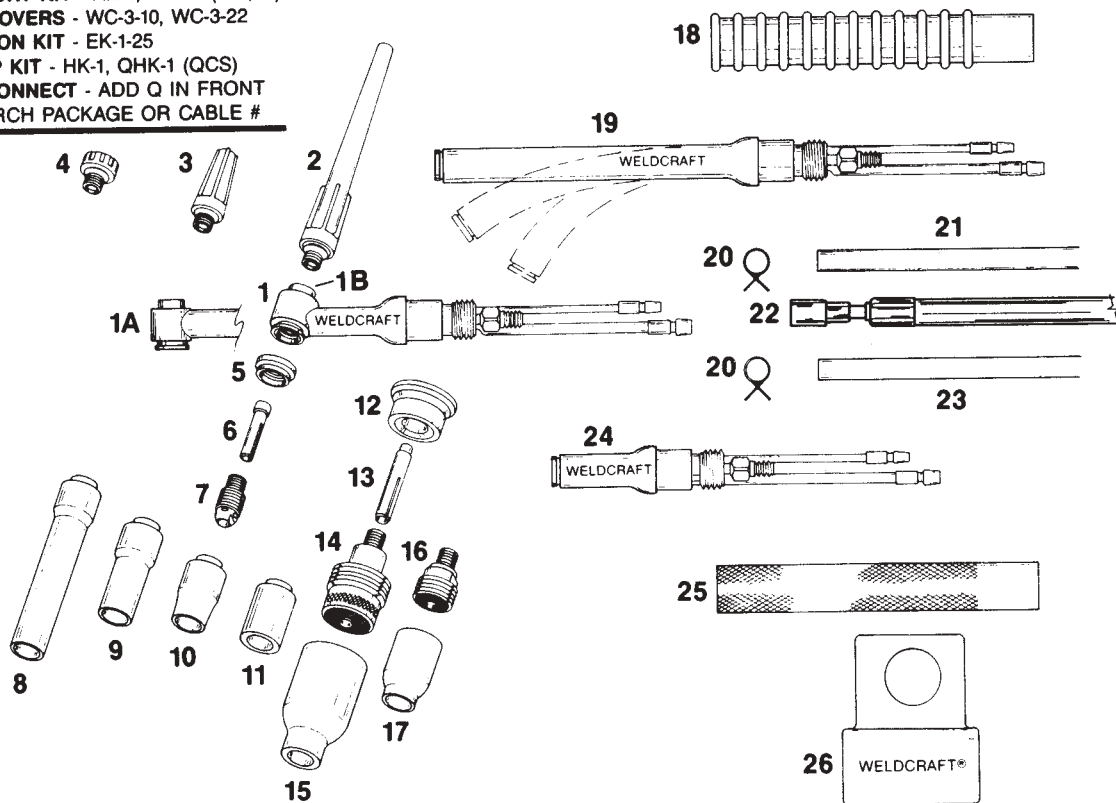

ITEM NO.	STOCK NO.	DESCRIPTION	ITEM NO.	STOCK NO.	DESCRIPTION
1	WP-20	Torch body, includes cup gasket (70°)	19	WP-25	Flexible torch body, includes cup gasket
1A	WP-20N	Torch body, same as WP-20, with 90° head	20	53N04	Hose clamp
1B	9-4	Insert	21	-	Gas hose 45V09 12½ ft. (3.8m), 45V09R 45V10 25 ft. (7.6m), 45V10R
2	41V24	Long back cap, includes 98W77 O-ring	22	-	Power Cable 45V03 12½ ft. (3.8m), 45V03R, 45V03HD 45V04 25 ft. (7.6m), 45V04R, 45V04HD
3	41V35	Medium back cap, includes 98W77 O-ring	23	-	Water hose 45V07 12½ ft. (3.8m), 45V07R, 45V07HD 45V08 25 ft. (7.6m), 45V08R, 45V08HD
4	41V33	Short back cap, includes 98W77 O-ring	24	WP-20P	Pencil torch body, includes cup gasket
5	598882	Cup gasket	25	53N06	Handle (smooth, standard)
6	-	Collet (See chart A)	26	45V11	Power cable adapter
7	-	Collet body (See chart A)			<b>Cable repair kits</b>
8	-	Extra long lava nozzle (See chart B)			ZCRK20 Power cable repair kit
9	-	Long lava nozzle (See chart B)			ZHRKG20 Gas hose repair kit
10	-	Alumina nozzle (See chart B)			ZHRKW20 Water hose repair kit
11	-	Lava nozzle (See chart B)			
12	54N63-20	Lg. Diameter gas lens insulator			
13	-	Lg. Diameter gas lens collet (See chart A)			
14	-	Lg. Diameter gas lens (See chart A)			
15	-	Lg. Diameter gas lens nozzle (See chart B)			
16	-	Gas lens (See chart A)			
17	-	Alumina gas lens nozzle (See chart B)			
18	53N06R	Handle (ribbed, optional)			

CHART A • COLLETS • COLLET BODIES • GAS LENS

Electrode Diameter	.020 (.5mm)	.040 (1mm)	1/16 (1.6mm)	3/32 (2.4mm)	1/8 (3.2mm)
Collet	13N20	13N21	13N22	13N23	13N24
Collet Body	13N25	13N26	13N27	13N28	13N29
Gas Lens	45V41	45V42	45V43	45V44	45V45
Lg. Dia. Gas Lens Collet	13N20L	13N21L	13N22L	13N23L	13N24L
Lg. Dia. Gas Lens	45V0204S	45V116S	45V64S	995795S	

CHART B • GAS NOZZLES \* HPN - HIGH PERFORMANCE NOZZLES AVAILABLE

SIZE	3	4	5	6	7	8	10	12	SHORT
Alumina	-	13N08	13N09	13N10	13N11	13N12	13N13	-	-
Alumina Gas Lens	-	53N58	53N59	53N60	53N61	63N61S	-	-	-
Lg. Dia. Gas Lens	-	-	-	57N75	-	57N74	53N88	53N87	53N89*
Lava	-	13N14	13N15	13N16	13N17	13N18	13N19	-	-
Long** Lava	796F70	796F71	796F72	796F73	-	-	-	-	-
Ex. Long Lava	796F74	796F75	796F76	796F77	-	-	-	-	-

Water cooled torches require cooling water flow of 1 quart (.94 liter) to 1½ quarts (1.4 liters) per minute at a maximum of 50 PSI pressure.

\*Not recommended for use with high frequency current.

\*\*Also available in Alumina. Example: A796F70.

WELDCRAFT, APPLETON, WISCONSIN 54911 U.S.A PH:920-882-6801 800-752-7620(USA ONLY) FAX:920-882-6840

An Illinois Tool Works Company • COPYRIGHT 1983 WELDCRAFT PRODUCTS, INC.