

Q5WGT Connection Diagram

Flo-thru gas for water-cooled torch

Water-cooled

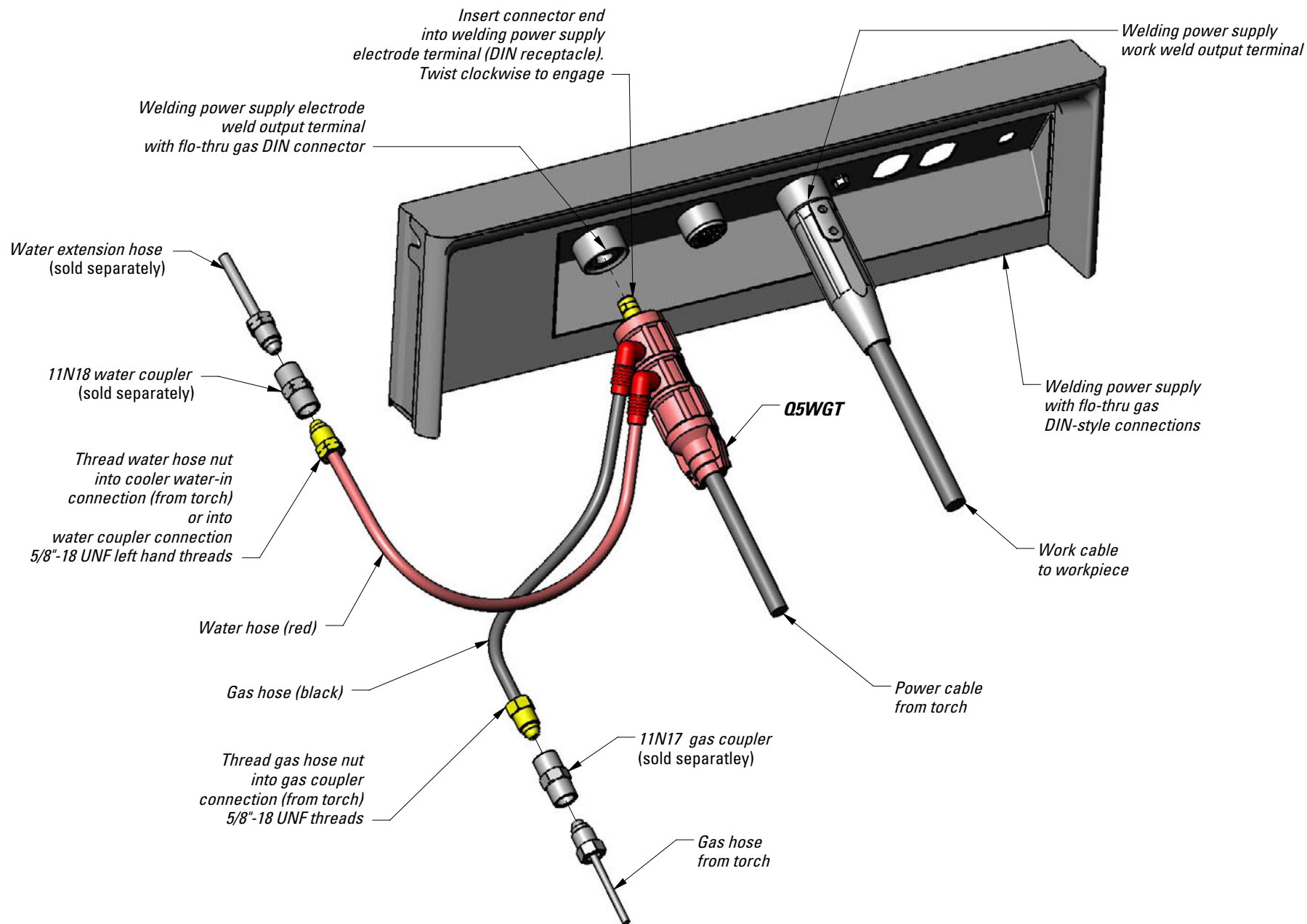

 Turn off power before connecting to weld output terminal.

Q5WGT Assembly Instructions

Water-cooled

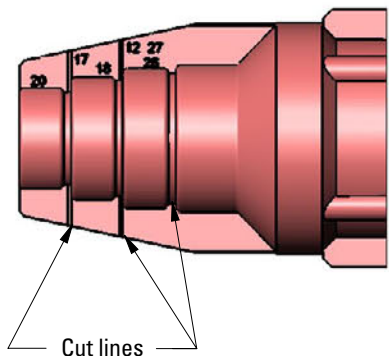

DETAIL A

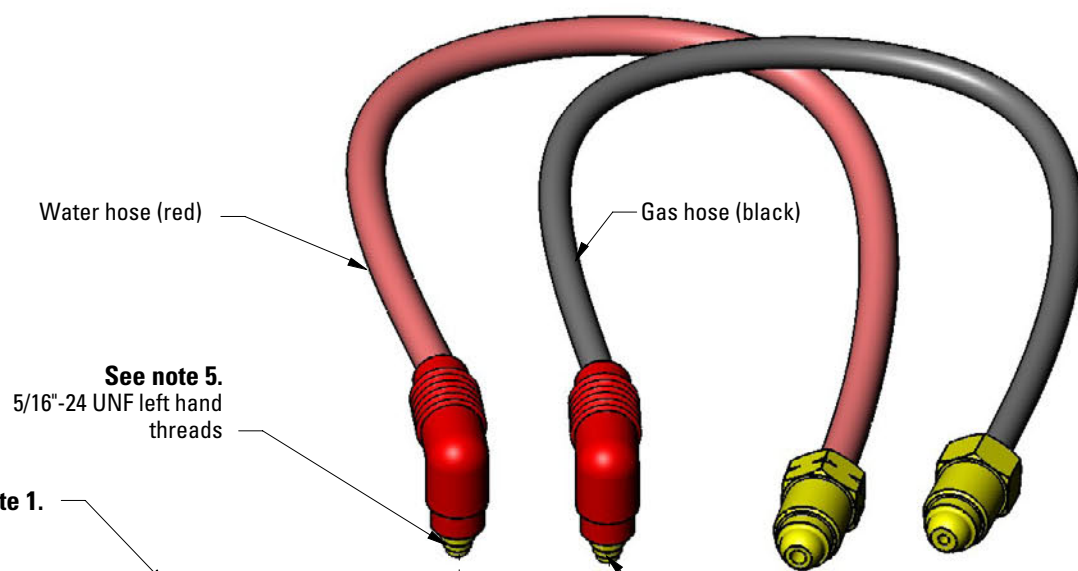

Power cable to torch

Q5WGT Assembly Notes

1. Cut along scribe lines on top and bottom insulators to appropriate power cable diameter (See DETAIL A)
2. Thread power cable nut into connector female threaded hole.
3. Assemble top and bottom insulators together with DIN connector in between insulator halves. Align threaded gas & water holes in DIN connector with holes in top insulator.
4. Assemble gas hose to DIN connector. Thread gas hose nut into DIN connector female threaded gas hole.
5. Assemble water hose to DIN connector. Thread water hose nut into DIN connector female threaded water hole. Note threads are left handed.

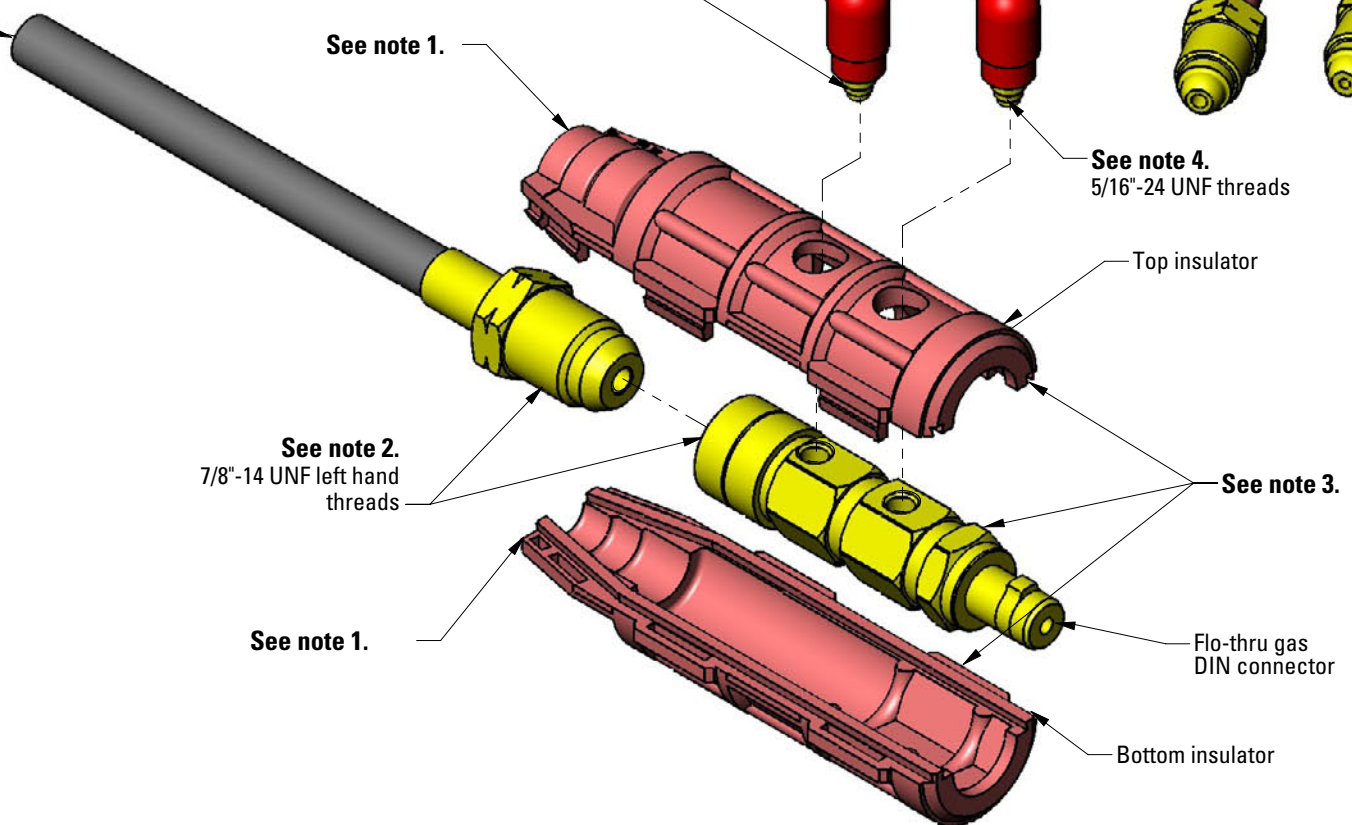

 Turn off power before connecting to weld output terminal.