

Q5W Connection Diagram Solid DIN with side water hose

Water-cooled

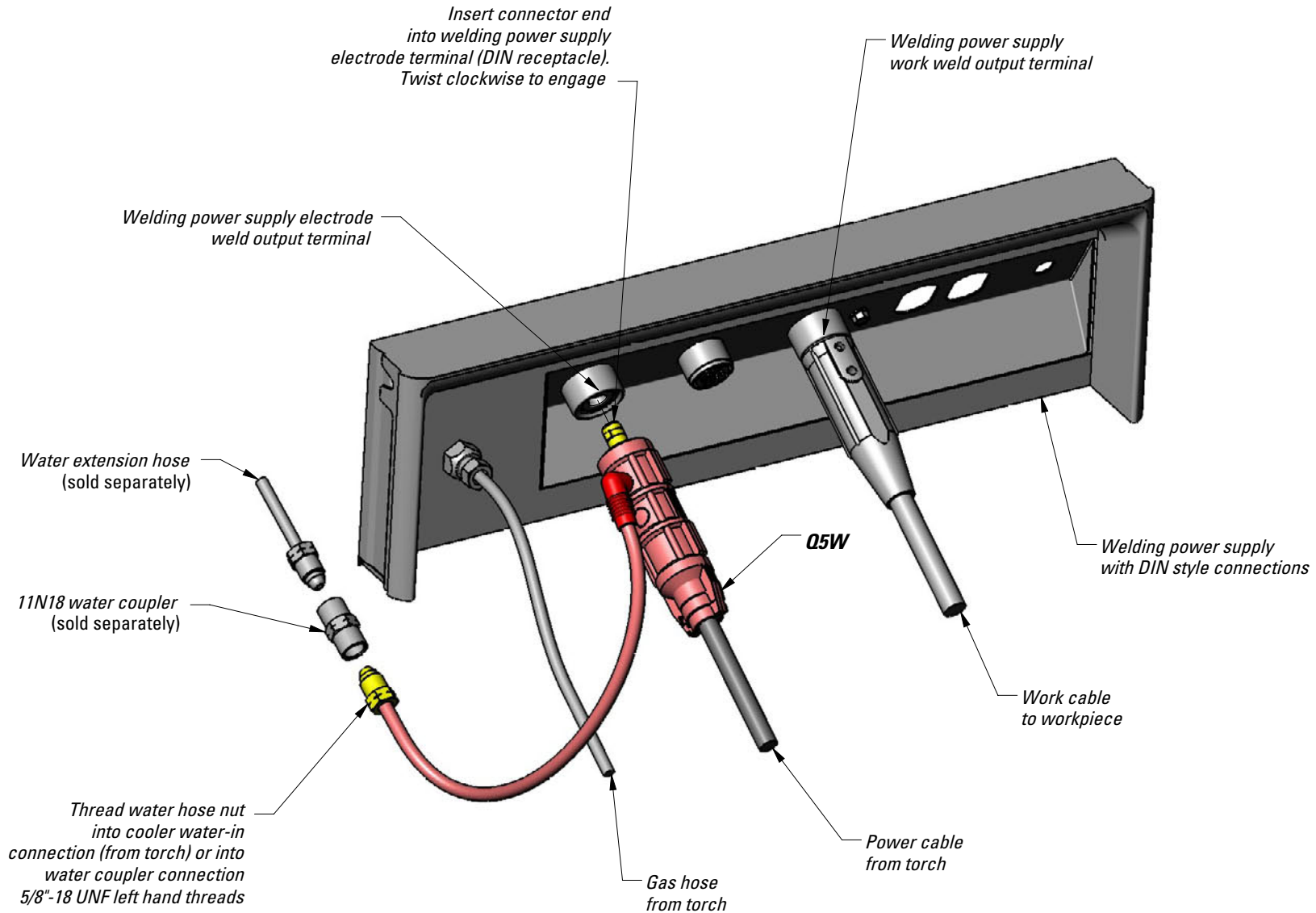

 Turn off power before connecting to weld output terminal.

Q5W Assembly Instructions

Water-cooled

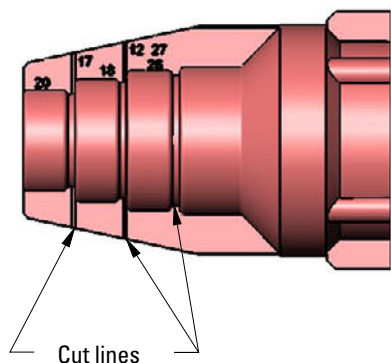

DETAIL A

Power cable to torch

Q5W Assembly Notes

1. Cut along scribe lines on top and bottom insulators to appropriate power cable diameter (See DETAIL A.)
2. Thread power cable nut into connector female threaded hole.
3. Assemble top and bottom insulators together with DIN connector in between insulator halves. Align threaded water hole in DIN connector with hole in top insulator.
4. Assemble water hose to DIN connector. Thread water hose nut into DIN connector female threaded water hole.

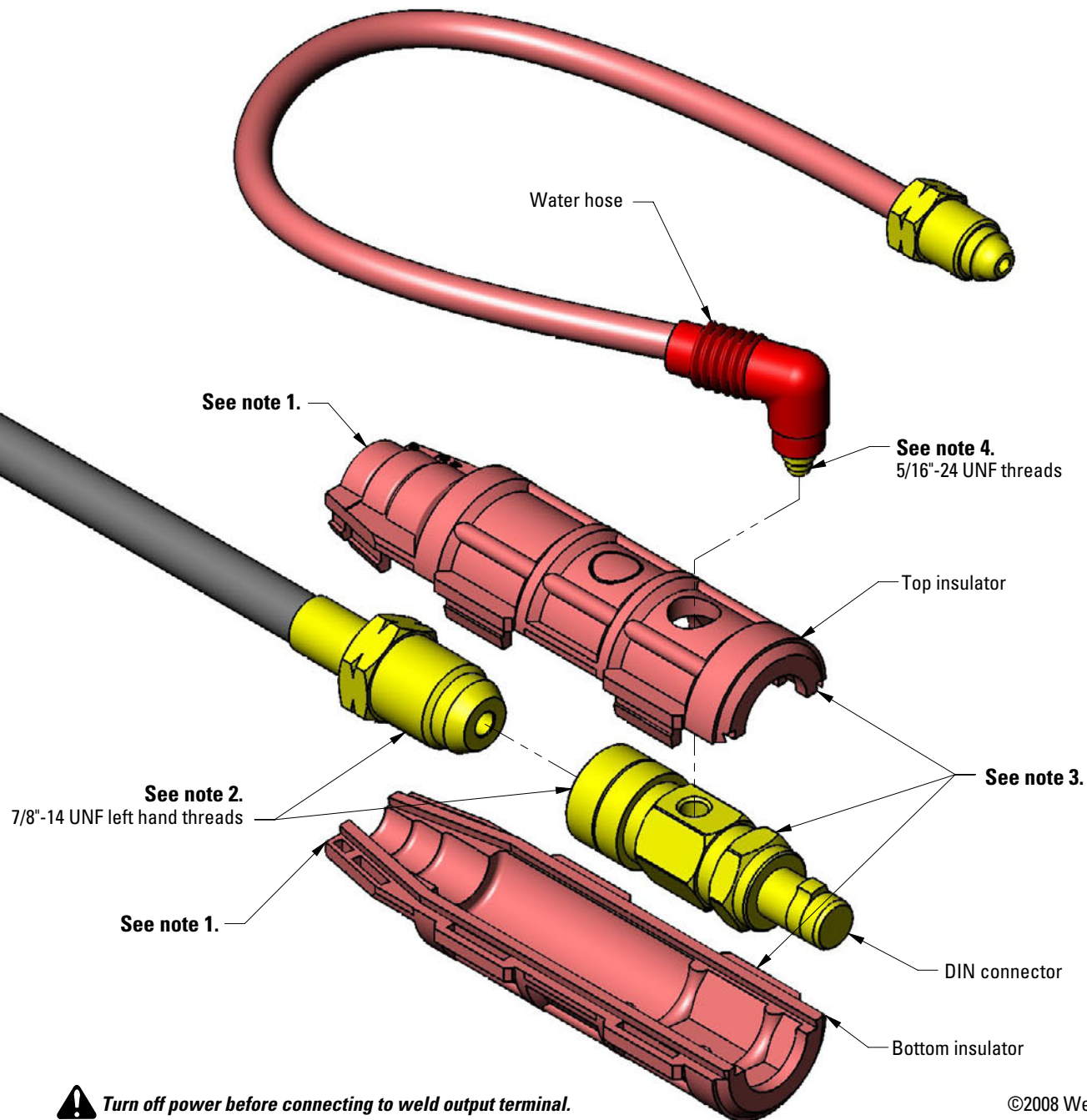

! Turn off power before connecting to weld output terminal.