

# Q5GT-200 Connection Diagram

## One-piece power cable, flo-thru gas DIN connector

Air-cooled

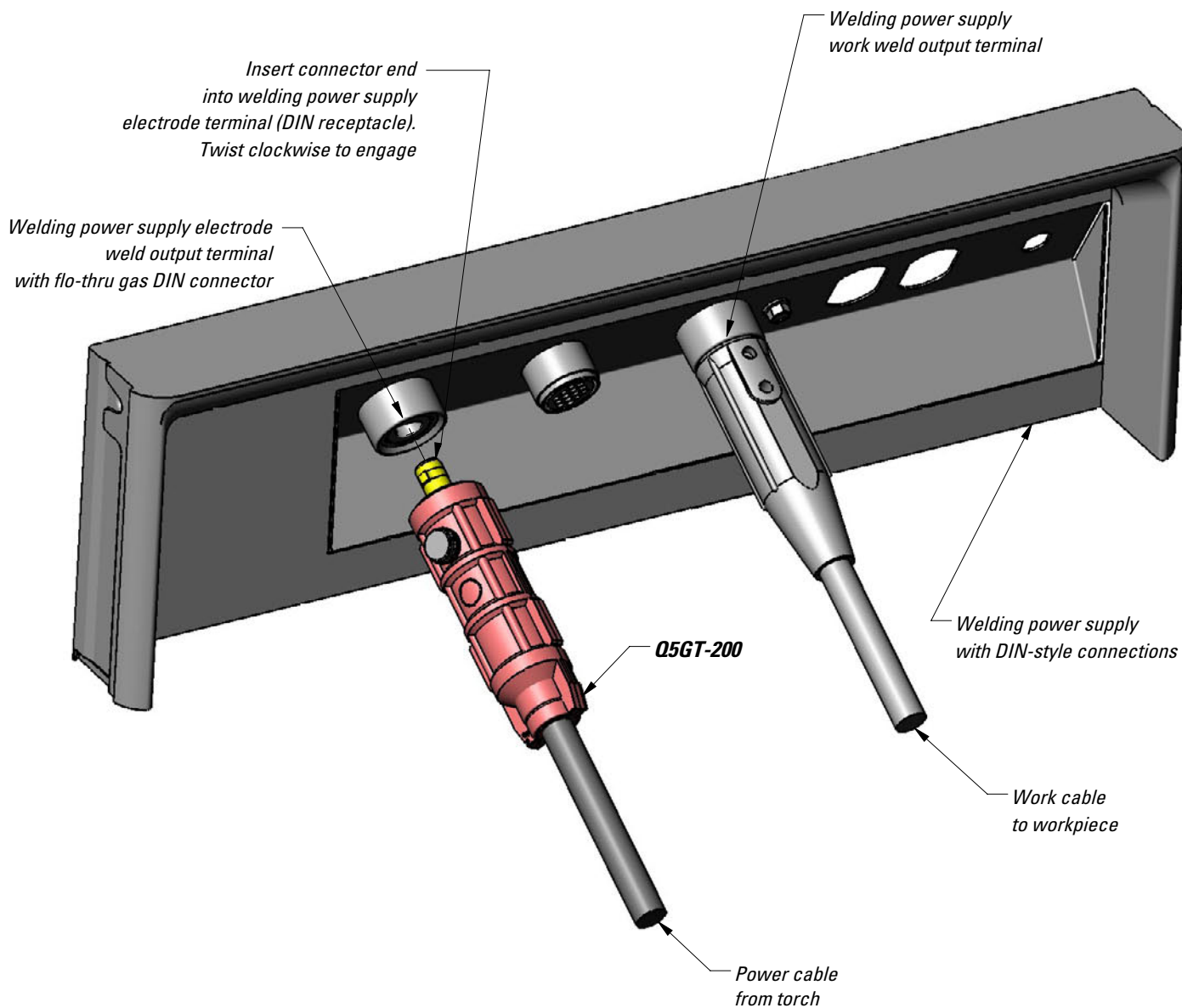

**!** Turn off power before connecting to weld output terminal.

# Q5GT-200 Assembly Instructions

*Air-cooled*

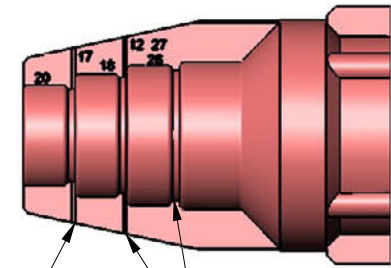

Cut lines

**DETAIL A**

Power cable from torch

### Q5GT-200 Assembly Notes

1. Cut along scribe lines on top and bottom insulators to appropriate power cable diameter (See DETAIL A)
2. Thread power cable nut into DIN connector female threaded hole.
3. Assemble top and bottom insulators together with DIN connector in between insulator halves. Align threaded plug hole in DIN connector with hole in top insulator.
4. Assemble threaded insulator plug to DIN connector.

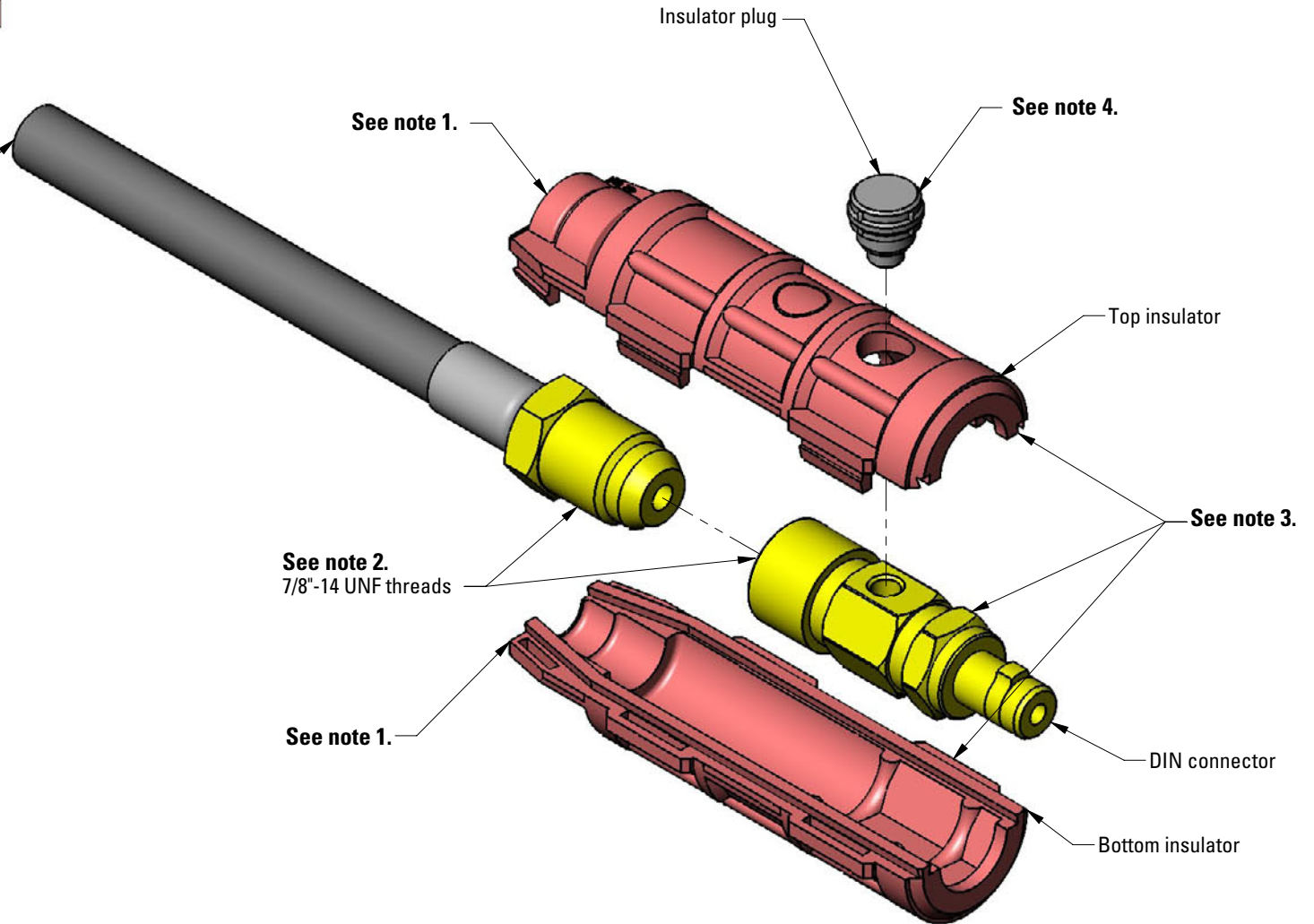

Turn off power before connecting to weld output terminal.