

Q5G-200 Connection Diagram

One-piece power cable, with side gas hose

Air-cooled

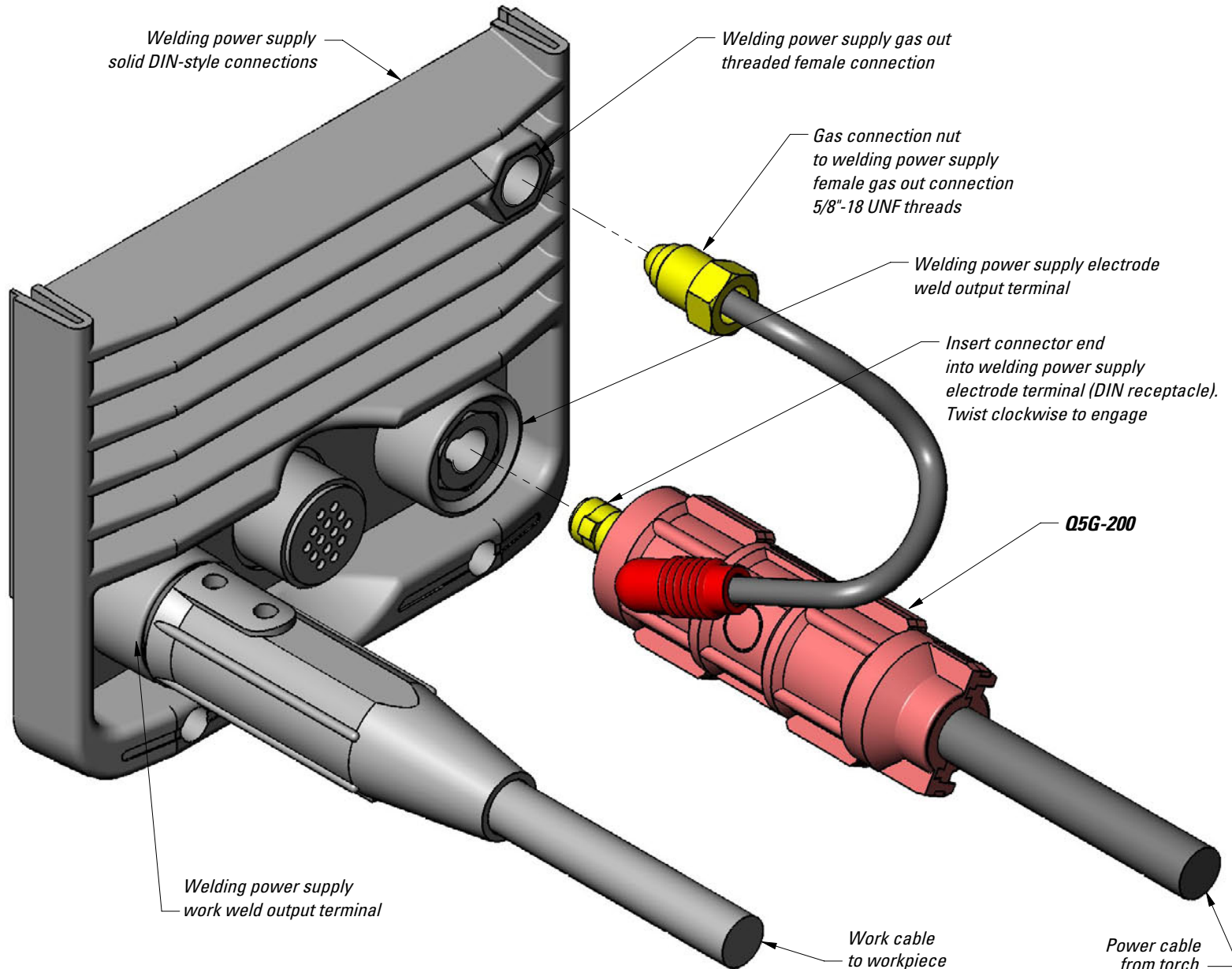

 Turn off power before connecting to weld output terminal.

Q5G-200 Assembly Instructions

Air-cooled

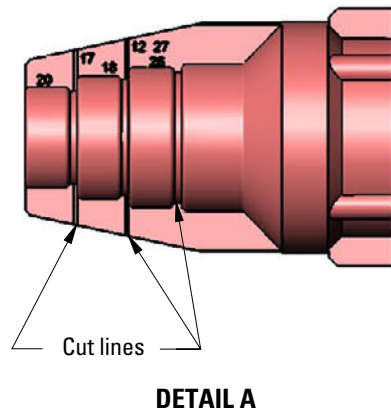

Power cable
to torch

See note 1.

Gas hose

See note 4.
5/16"-24 UNF threads

Q5G-200 Assembly Notes

1. Cut along scribe lines on top and bottom insulators to appropriate power cable diameter (See DETAIL A)
2. Thread power cable nut into connector female threaded hole.
3. Assemble top and bottom insulators together with DIN connector in between insulator halves. Align threaded gas hole in DIN connector with hole in top insulator.
4. Assemble gas hose to DIN connector. Thread gas hose nut into DIN connector female threaded gas hole.

Top insulator

See note 3.

See note 2.
7/8"-14 UNF threads

See note 1.

DIN connector

Bottom insulator

 Turn off power before connecting to weld output terminal.