

Q5G-150 Connection Diagram

One-piece power cable, with side gas hose

Air-cooled

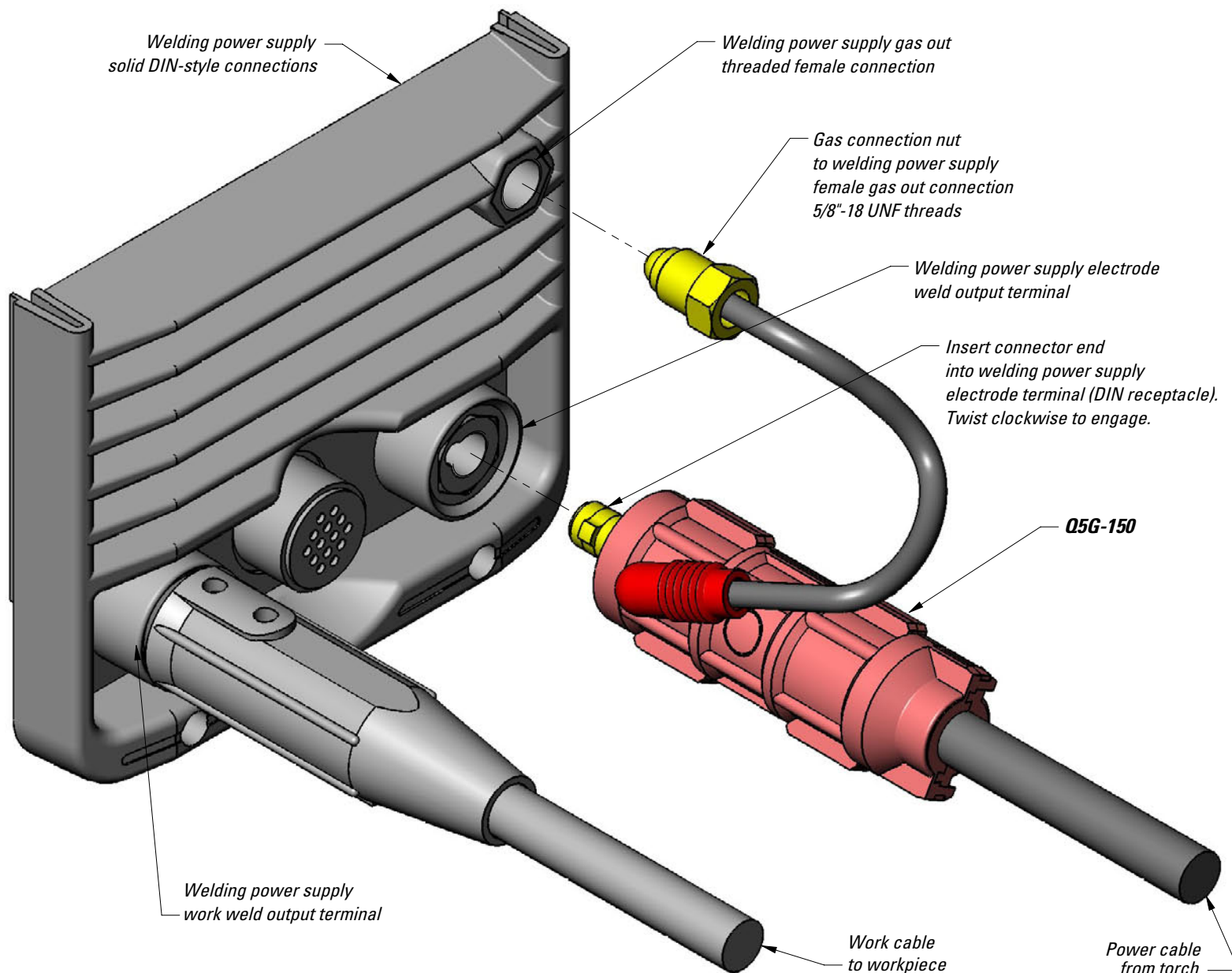

! Turn off power before connecting to weld output terminal.

Q5G-150 Assembly Instructions

Air-cooled

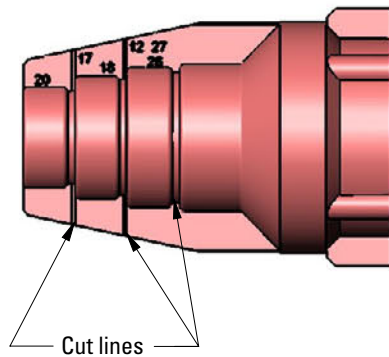

DETAIL A

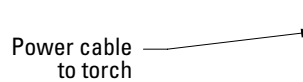
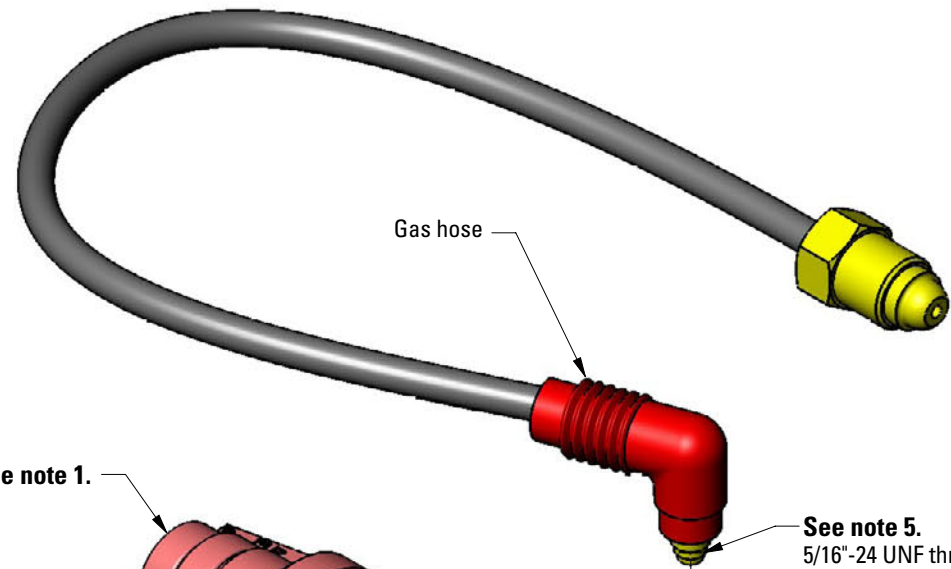

Q5G-150 Assembly Notes

1. Cut along scribe lines on top and bottom insulators to appropriate power cable diameter (See DETAIL A)
2. Thread power cable adaptor onto male DIN connector threads.
3. Thread power cable into power cable adaptor.
4. Assemble top and bottom insulators together with DIN connector in between insulator halves. Align threaded gas hole in DIN connector with hole in top insulator.
5. Assemble gas hose to DIN connector. Thread gas hose nut into DIN connector female threaded gas hole.

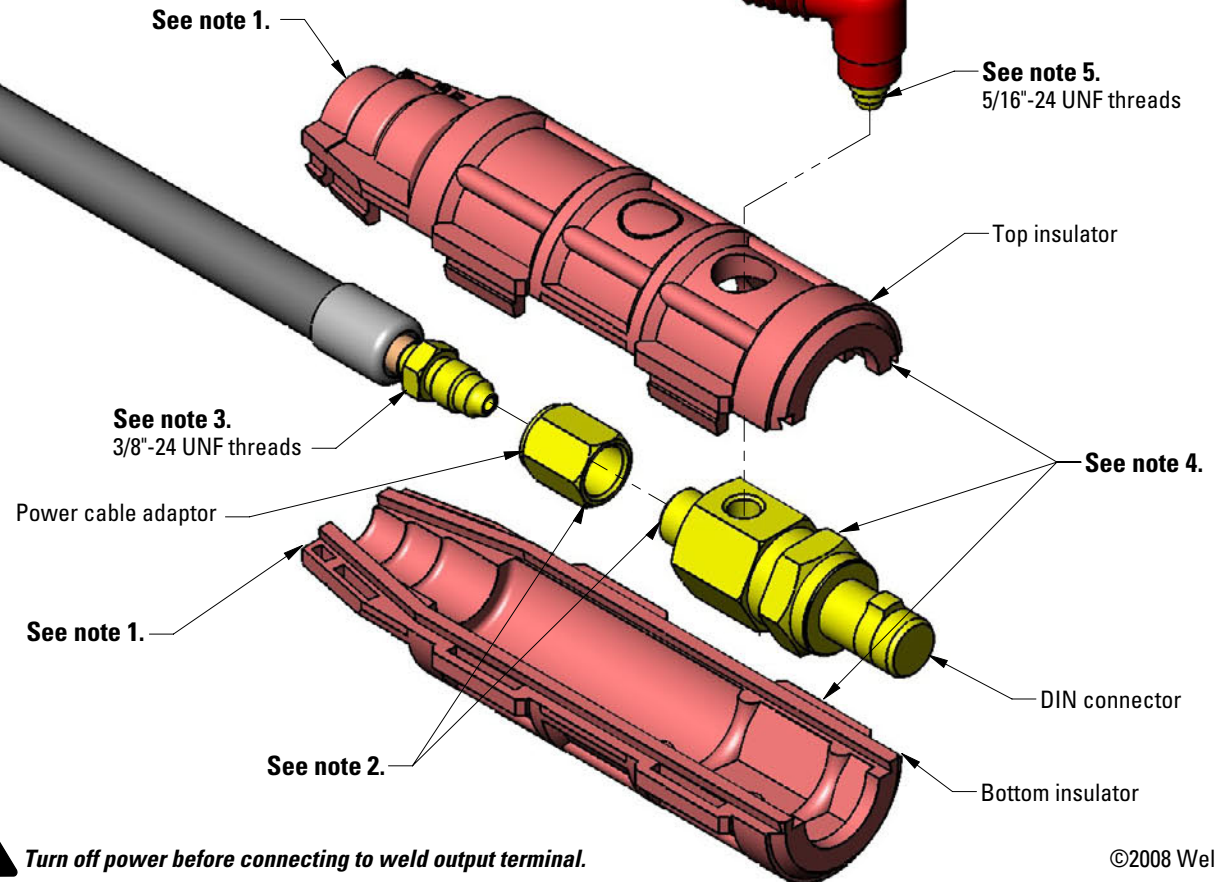

! Turn off power before connecting to weld output terminal.