

Q5 Connection Diagram Two-piece power cable

Air-cooled

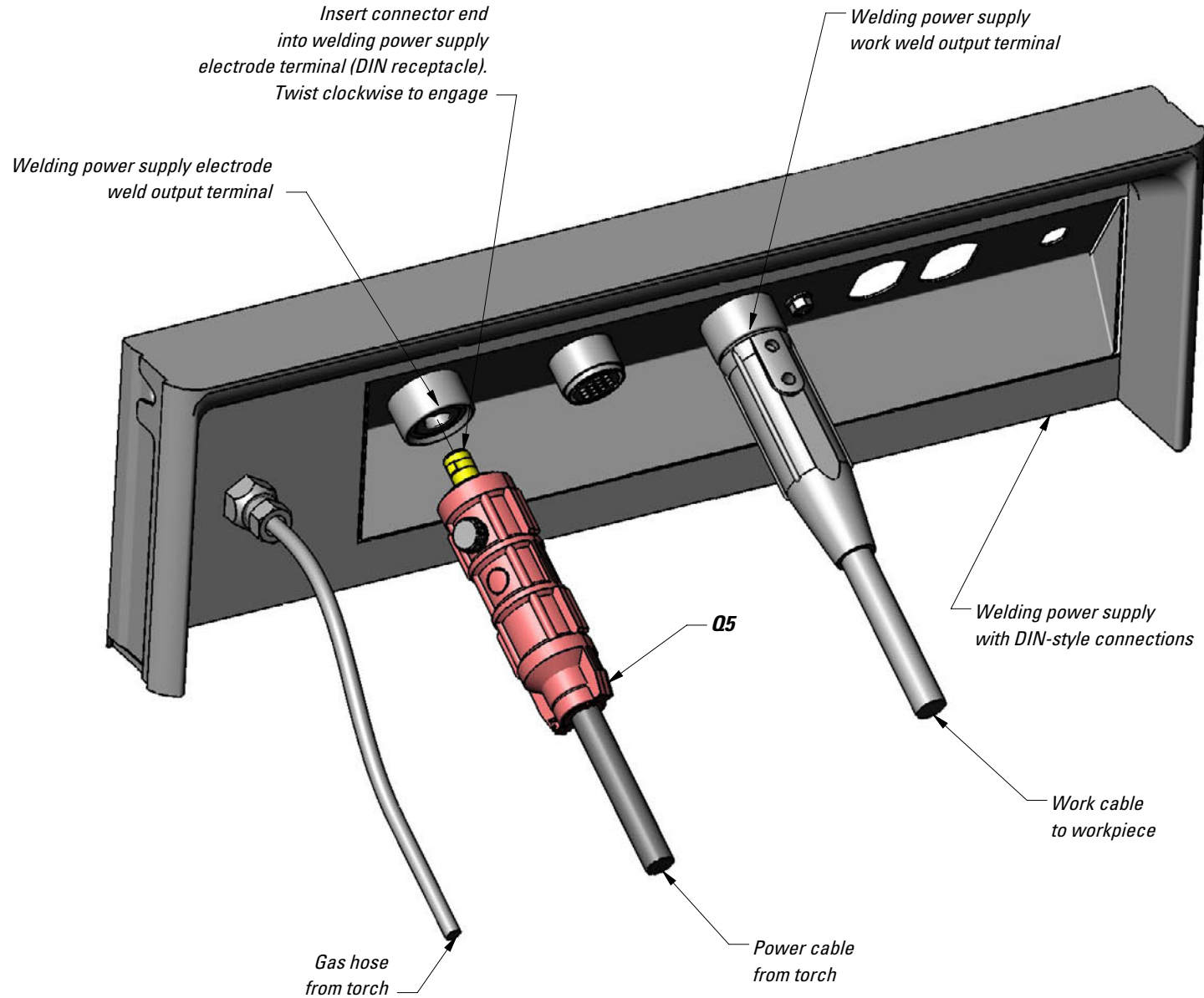

! Turn off power before connecting to weld output terminal.

Q5 Assembly Instructions

Air-cooled

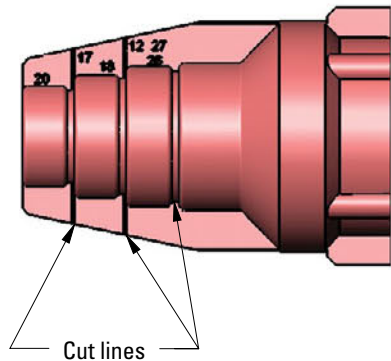

DETAIL A

Power cable from torch

Q5 Assembly Notes

1. Cut along scribe lines on top and bottom insulators to appropriate power cable diameter (See DETAIL A.)
2. Remove any terminal from machine end of power cable. Strip approximately 1" insulation back from bare conductor.
3. Insert bare conductor of power cable in DIN connector. Fasten power cable to DIN connector with supplied set screw.
4. Assemble top and bottom insulators together with DIN connector in between insulator halves. Align threaded plug hole in DIN connector with hole in top insulator.
5. Assemble threaded insulator plug to DIN connector.

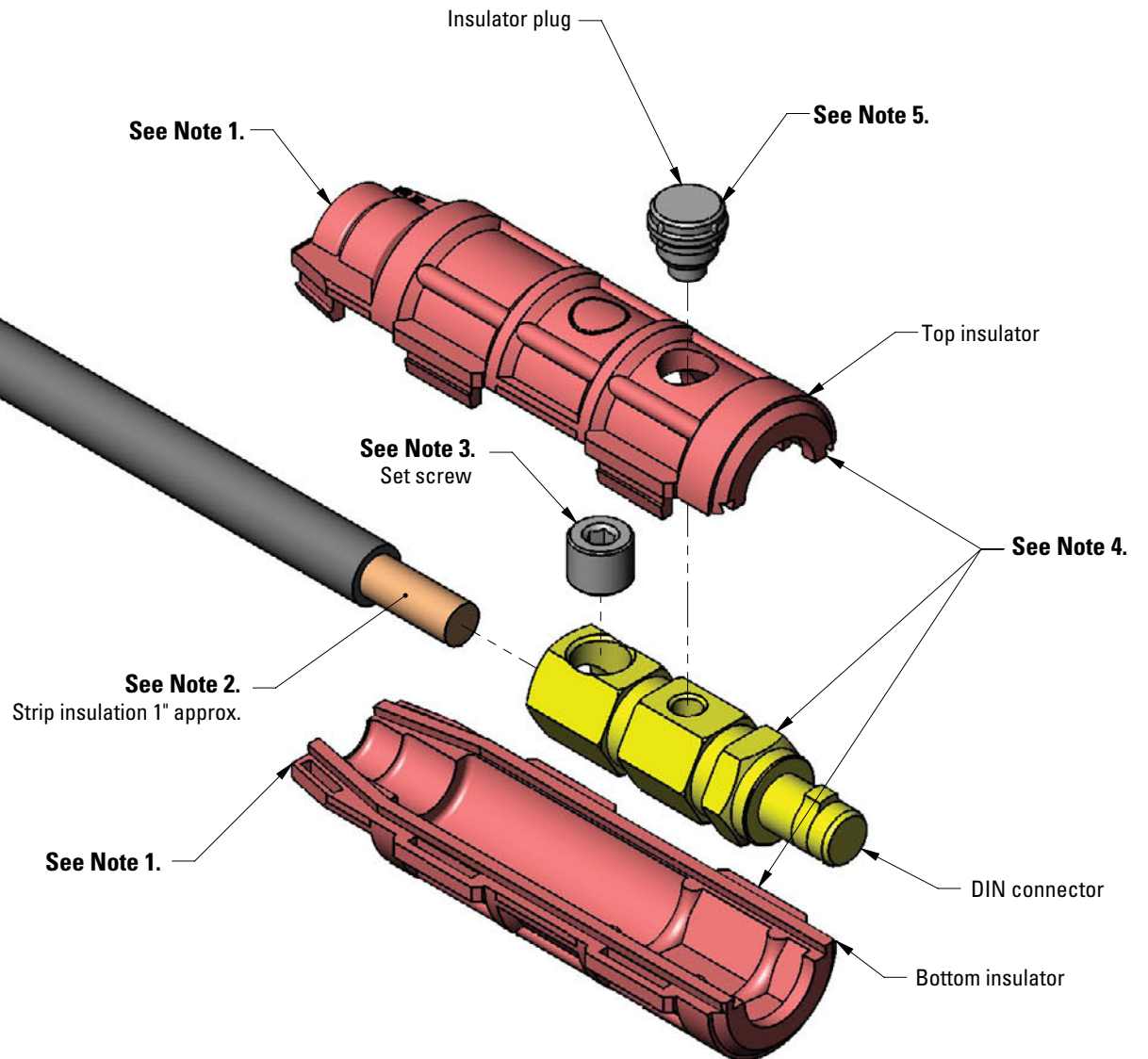

! Turn off power before connecting to weld output terminal.